

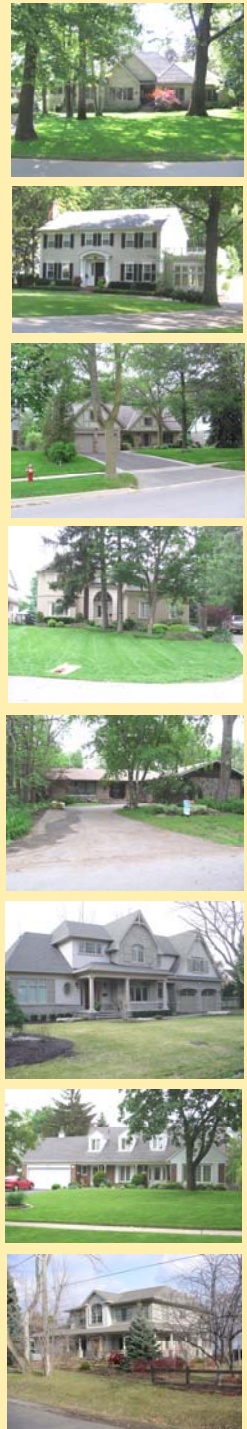

Design Guidelines and Site Plan Requirements



New Dwellings, Replacement Housing and Additions

Planning and Building Department, Development and Design Division
www.mississauga.ca

Table of Contents

Part 1.0 Introduction

1.1 Purpose _____	4
-------------------	---

Part 2.0 Guidelines

2.1 Guidelines _____	8
2.2 Principle – Scale and Character _____	9
2.3 Principle – Massing _____	11
2.4 Principle – Building Height _____	15
2.5 Principle – Materials _____	17
2.6 Principle – Grades _____	18
2.7 Principle – Garages _____	19
2.8 Principle – Driveways/Hard Surface _____	20
2.9 Principle – Natural Environment Preservation and Protection _____	25

Part 3.0 Site Plan Process and Requirements

3.1 Site Plan Process Chart _____	30
3.2 Who Gets Circulated _____	31
3.3 Site Plan Application Requirements _____	32
3.4 Securities _____	36
3.5 Hoarding _____	38
3.6 Tree Removal Permission _____	39
3.7 Site Plan Undertaking _____	39
3.8 Site Plan Approval _____	39
3.9 Site Work Inspection _____	40
3.10 Glossary of Term _____	41
3.11 Sample Site Plan _____	42
3.12 Sample Building Elevations _____	43
3.13 Sample Floor Plans _____	44

Part 4.0 Conclusion

4.1 Keep your neighbours informed _____	47
4.2 Guidelines for a successful project _____	47

Part 5.0 Appendices

Appendix 'A' Average Grade Calculations _____	50
Appendix 'B' Credit Valley Conservation Process Chart _____	51



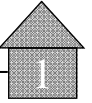

**PART 1.0
INTRODUCTION**

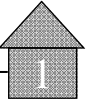

1.1

Purpose

Mississauga Council has designated specific areas in the City as SITE PLAN CONTROL areas under the Site Plan Control By-law to ensure that the construction of new dwellings, replacement housing and additions retain and complement the overall character of the community's existing housing stock and natural areas, and contribute to the diversity and unique qualities of the neighbourhood.

SITE PLAN CONTROL is the first-step review and approval of development proposals. In SITE PLAN CONTROL areas, City Council has endorsed specific design guidelines for dwellings. These guidelines are applied when the City reviews Site Plan applications.

As a first step in the process, applicants and their design consultants are to arrange a preliminary meeting with the Development and Design Division to review "concept" drawings. At this meeting, any questions or issues regarding the proposed plan can be addressed before the Site Plan application is formally submitted.

Note: The City first must grant Site Plan approval before a Building Permit can be issued. Applicants must also refer to the City's Official Plan and the Zoning By-law to ensure that the applicable policies and requirements in these documents are met.

The purpose of this document is to assist home owners, designers, architects and landscape architects by outlining the framework and design principles on which the guidelines for Site Plan approval are based. Photo and diagram examples are included to clearly demonstrate the preferred design options that meet the City's design guidelines.

For more information about the Site Plan approval process, please contact the Development and Design Division, Planning and Building Department at 905-896-5511.

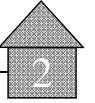

**PART 2.0
DESIGN GUIDELINES**

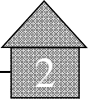

2.1

Guidelines

These guidelines are intended to ensure that new developments are compatible with, and enhance existing neighbourhoods by promoting design that takes into consideration and complements the architecture and streetscapes of neighbouring buildings, while still allowing for and encouraging diverse design solutions. It is not the intent of these guidelines to restrict design flexibility or creativity, but to encourage architects and designers to avoid the potential conflicts that may arise if design principles are not followed.

These guidelines deal with scale (buildings proportion to the surrounding buildings), massing (proportion of building to property), and character of proposed buildings and/or additions, as well as siting of proposed dwellings and/or additions relating to tree protection, garage location, driveway location, and grading.

Applicants must also refer to the City's Official Plan and the Zoning By-law to ensure that the applicable policies and requirements in these documents are also met when preparing design proposals and solutions.

For each design consideration, this document includes a design principle and provides the appropriate design guideline(s) to address the issue. For additional clarification, photo examples demonstrate "preferred" and "not preferred" examples for each principle and guideline.

2.2

Principle – Scale and Character

House designs which fit with the scale and character of the local area and take advantage of a particular site are encouraged. The use of standard, repeat designs is strongly discouraged.



2.2.1 Guideline:

Each site is unique, however new dwellings and/or additions should be designed to fit with the scale and character of the particular site and its context.



Preferred



Not Preferred

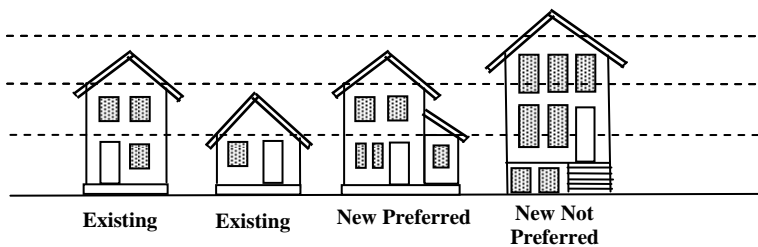

2.3

Principle – Massing

Preserve and enhance the generous front, rear and side yard setbacks. The building mass, side yards and rear yards should respect and relate to those of the adjacent lots, and new houses and/or additions should not have a detrimental impact on the immediate neighbours in terms of loss of privacy or sunlight. The massing of a building is a key factor in the successful integration of a new house and/or additions.

2.3.1 Guideline:

The massing of the dwelling should be consistent with the adjacent homes.



Preferred



Not Preferred

2.3.2 Guideline

Existing generous front and rear yards should be maintained.

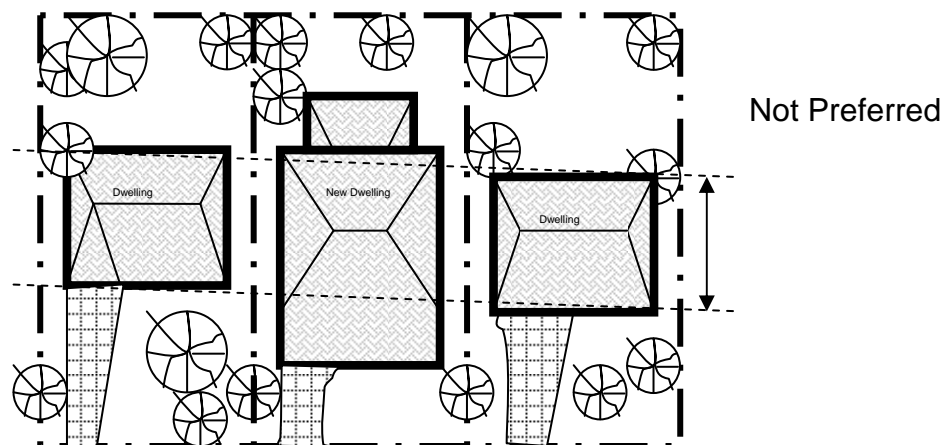
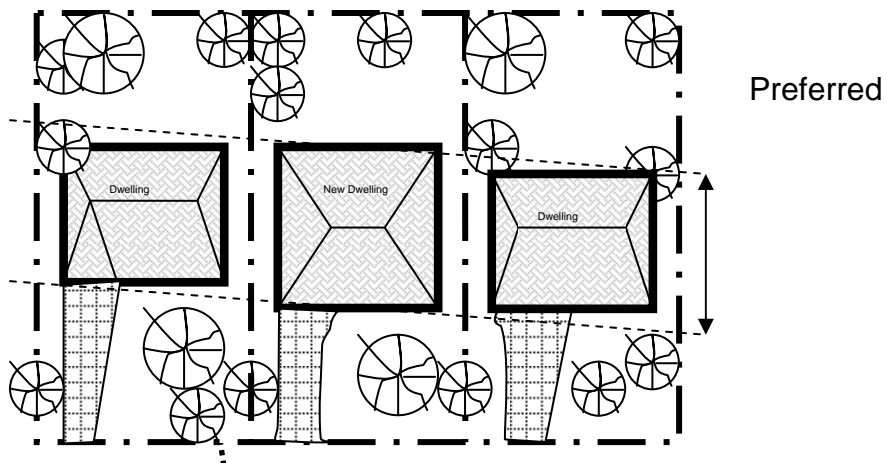

2.3.3 Guideline:

Second storey balconies that create an overlook condition onto adjacent properties are discouraged.

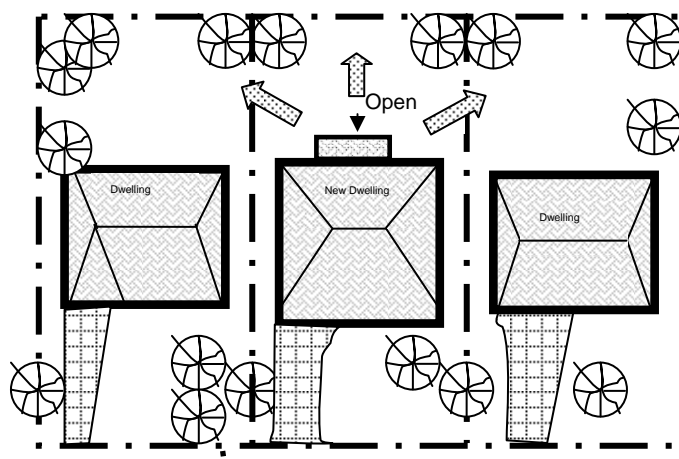

Guidelines

2.3.3 Guideline

Existing generous side yards should be maintained. Second storey additions should meet the minimum by-law requirements,. However where setbacks cannot be met due to existing conditions, second storey additions should be designed to de-emphasize the impact along the side yard. As shown in the preferred condition below, the second storey has been set back from the limits of the ground floor, providing for a roof design that slopes down to the first floor level.

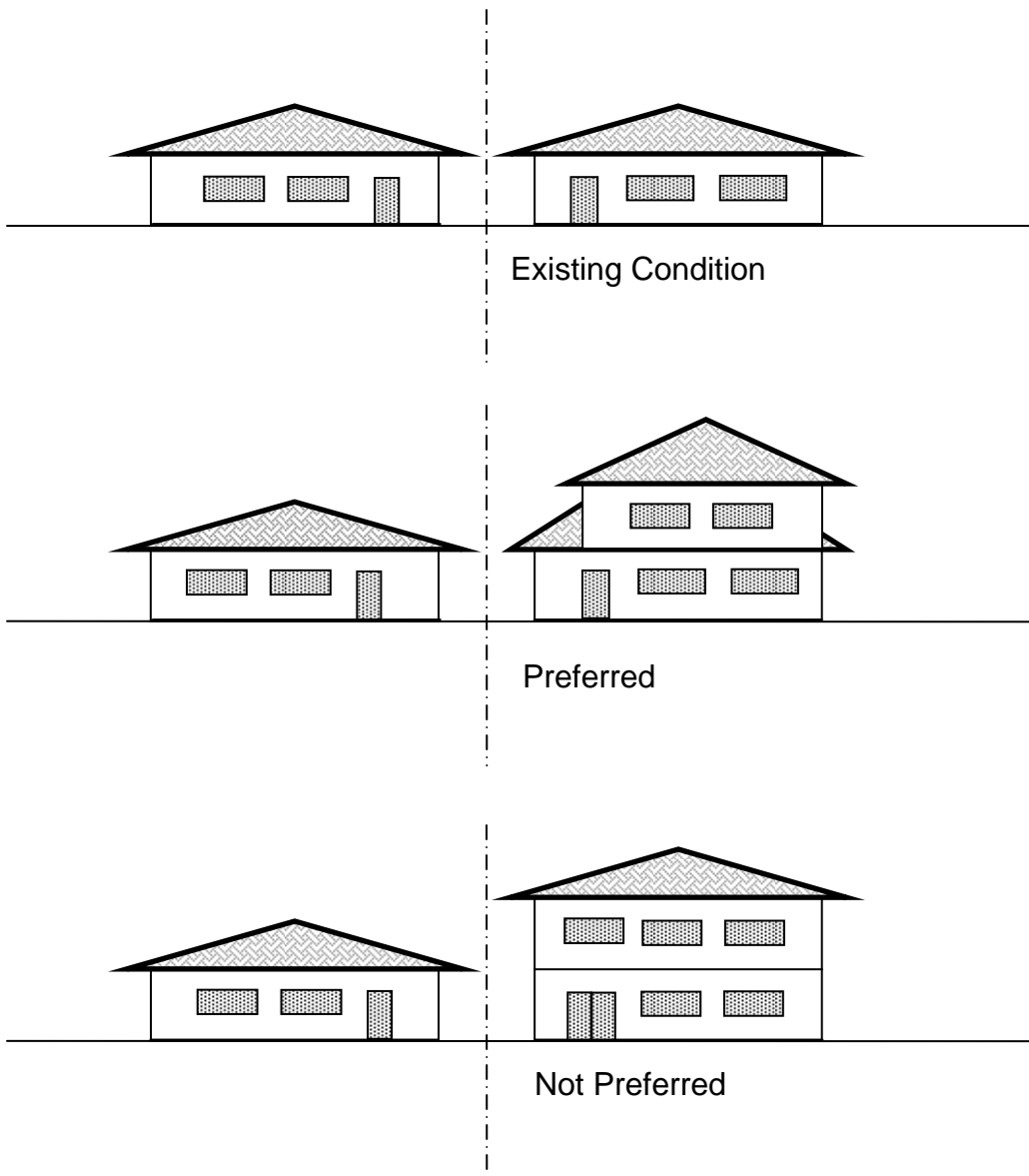



Preferred

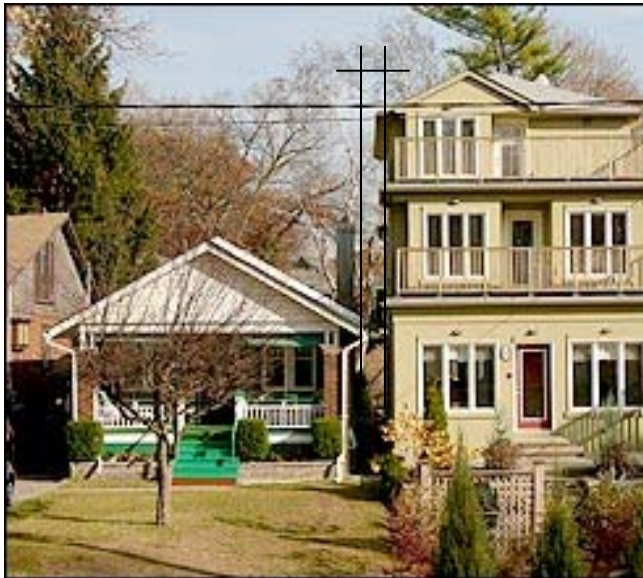

Not Preferred

2.4

Principle – Building Height

Encourage buildings to be one to two storeys in height. The design of the building should de-emphasize the height of the house and be designed as a composition of small architectural elements (i.e. projecting dormers and bay windows where applicable).

2.4.1 Guideline:

Where applicable, the front wall of the roof mass should be designed as a composition of small architectural elements (i.e. projecting dormers, broken down wall planes, porches, etc. as opposed to a single face two-storey high front wall with occasional bay windows and 45 degree, two-storey high roof.)



Preferred



Not Preferred

2.4.2 Guideline:

The design of the dwelling should not appear to be higher than existing dwellings.



Preferred



Not Preferred

2.4.3 Guideline:

The use of two-storey elements is discouraged.



Not Preferred

Guidelines

2.5

Principles – Materials

Materials and building additions should complement the existing structure. New construction should complement existing materials in the neighbourhood.

2.5.1 Guideline

Materials that are compatible with the existing community and existing structure should be used.



Brick



Wood



Siding



Stone



Combination of materials



2.6

Principles – Grades

Existing grades should be maintained. The design of the house should take into consideration the existing grades and ensure that they are compatible with the finished grades of the neighbouring properties.

2.6.1 Guideline:

Existing grades should not be altered.

2.6.2 Guideline:

Existing grades within the site should be maintained within and adjacent to tree preservation areas.



Preferred



Not Preferred

2.7

Principle – Garages

Garages should be recessed or located behind the main face of the house. Projecting garages will be discouraged.

Alternatively garages should be recessed or located in the rear of the property.

2.7.1 Guideline:

Garages should be located behind or in line with the front door of the house to ensure visibility to the street and to ensure that the garage is not the dominant feature of the house.



Preferred

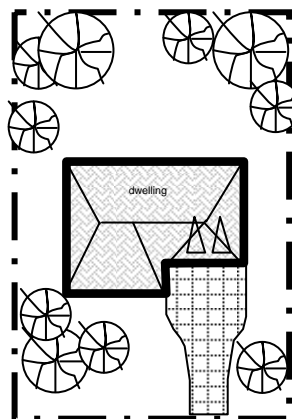

Not Preferred

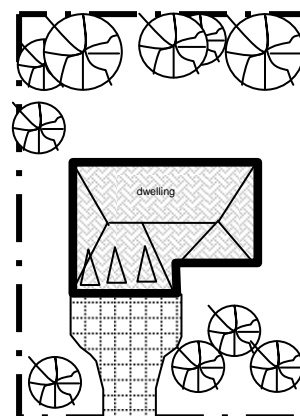

2.8

Principle – Driveways/Hard Surface

The proportion of paved surface in the front yard should be as small as possible. Large areas of paving in the front yard detract from the well landscaped image, which prevails in many neighbourhoods.

2.8.1 Guideline:

The greatest proportion of paved surface should be located directly in front of the garage. Paved surfaces should not result in additional parking spaces in the front yard of a dwelling.



Preferred

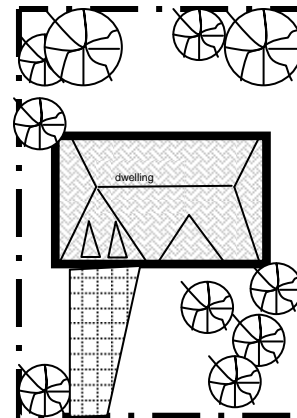

Not Preferred

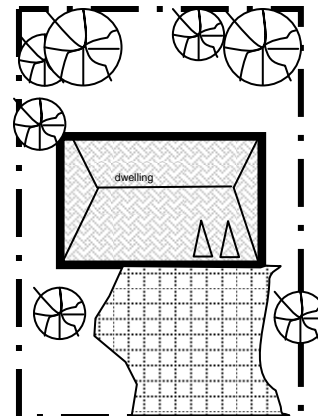

Guidelines

2.8.2 Guideline:

Circular driveways for properties under Site Plan Control will only be considered on larger lots where no existing trees are impacted and where there is ample room for landscaping.

Circular driveways should be used only for access purposes. They should not be installed to provide additional parking to the dwelling and should not be used in conjunction with a side loaded garage and/or hammerhead configuration.

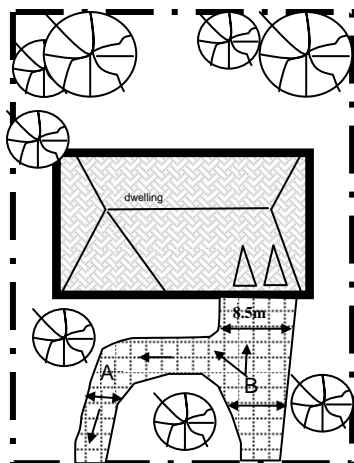

The driveway width should not be greater than 8.5 m (27.9 ft.) at any point, or a combination of points (see sketch)

$A + B = 8.5 \text{ m (27.9 ft.)}$ maximum driveway width

The maximum coverage of a front and/or exterior side yard by a driveway shall not exceed 50%



Preferred



Not Preferred

2.8.3 Guideline:

Increased driveway width for wide garages should be as small as possible. Hard surface material for driveways shall only be permitted in front of the garage where it is providing direct vehicular access.

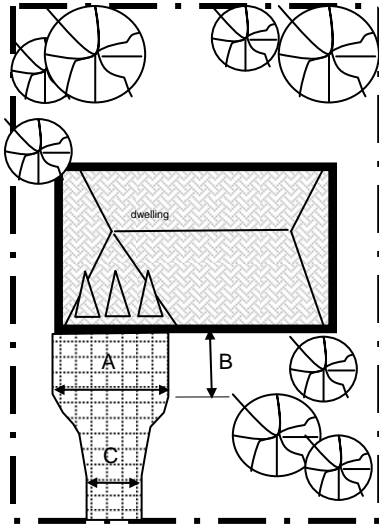

- A= 10.5 m (34.4 ft.) maximum driveway width
- B= 6.0 m (19.7 ft.) maximum
- C= Lesser of 50% of lot width of 8.5 m (27.9 ft.)

Maximum coverage of a front yard by a driveway shall be no more than 50%



Preferred



Not Preferred

Guidelines

2.8.4 Guideline:

Side loaded garages should:

- have a minimum of 1.5 m (4.9 ft.) of landscape area between the driveway portion and the neighbouring property;
- have a minimum 6.0 m (19.7 ft.) driveway width to ensure vehicles can properly manoeuvre out of the driveway;
- have a minimum of 50% habitable rooms facing the street, other than the garage to ensure a street presence;
- ensure that existing grades are maintained;
- should not be constructed in conjunction with a circular driveway.



Preferred

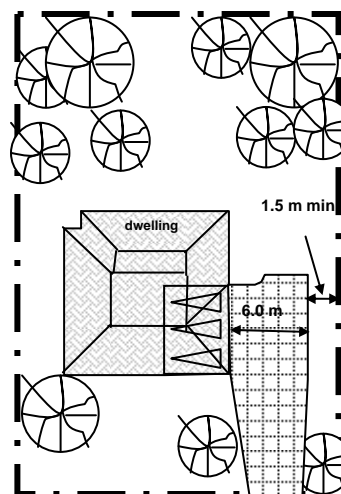

Not Preferred

2.8.5 Guideline:

Reverse grade driveways are discouraged and MAY only be considered in two instances:

- The first is where the topography of the land permits gravity drainage (ravine lot).
- The second is where a municipal storm sewer exists of sufficient capacity and depth to permit a storm sewer lead to drain (via gravity) from the low point of the driveway to the municipal sewer. The garage sill elevation shall be 1.0 m (3.28 ft.) above the municipal sewer obvert and the lead must be constructed to municipal standards.



Not Preferred



Not Preferred

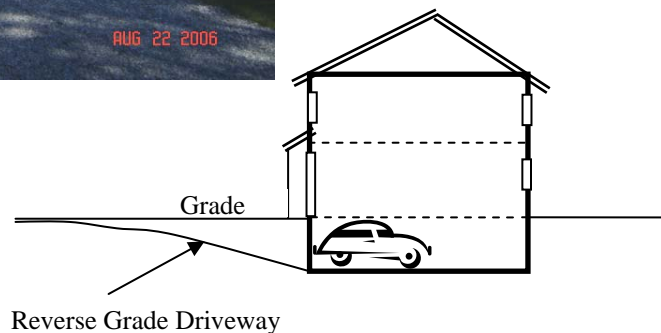

2.9

Principle – Natural Environment Preservation and Protection

Preservation and protection of trees on private and public property is vital to the character of existing neighbourhoods. As many existing trees and landscape features as possible should be preserved (ie. stone walls, fences, hedgerows, etc.).

2.9.1 Guideline:

Trees should be preserved and protected. It is recommended that home owners engage the services of a certified arborist to assess the health and condition of the existing trees and to make recommendations with regard to the preservation measures, including the siting of the house.

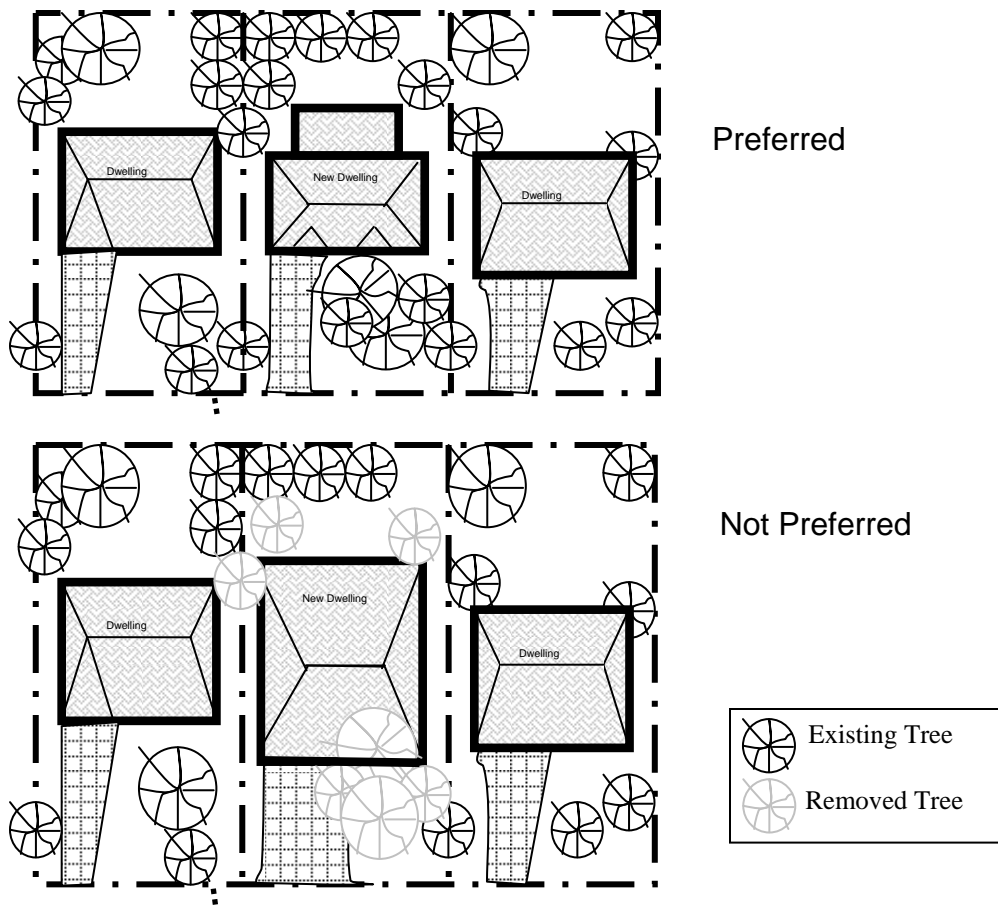

In situations where existing vegetation is removed to accommodate development, replacement planting may be required to ensure the streetscape character is maintained.

2.9.2 Guideline:

The location or relocation of utilities should be such that the impact on existing landscape features is minimized.

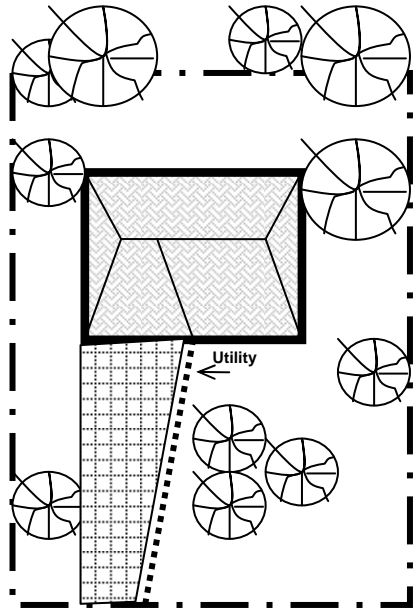

Preferred

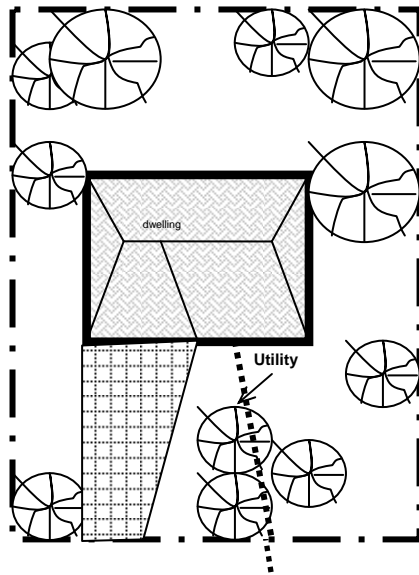

Not Preferred

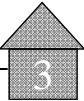

**PART 3.0
SITE PLAN PROCESS
AND REQUIREMENTS**

3.1

Site Plan Process: Chart

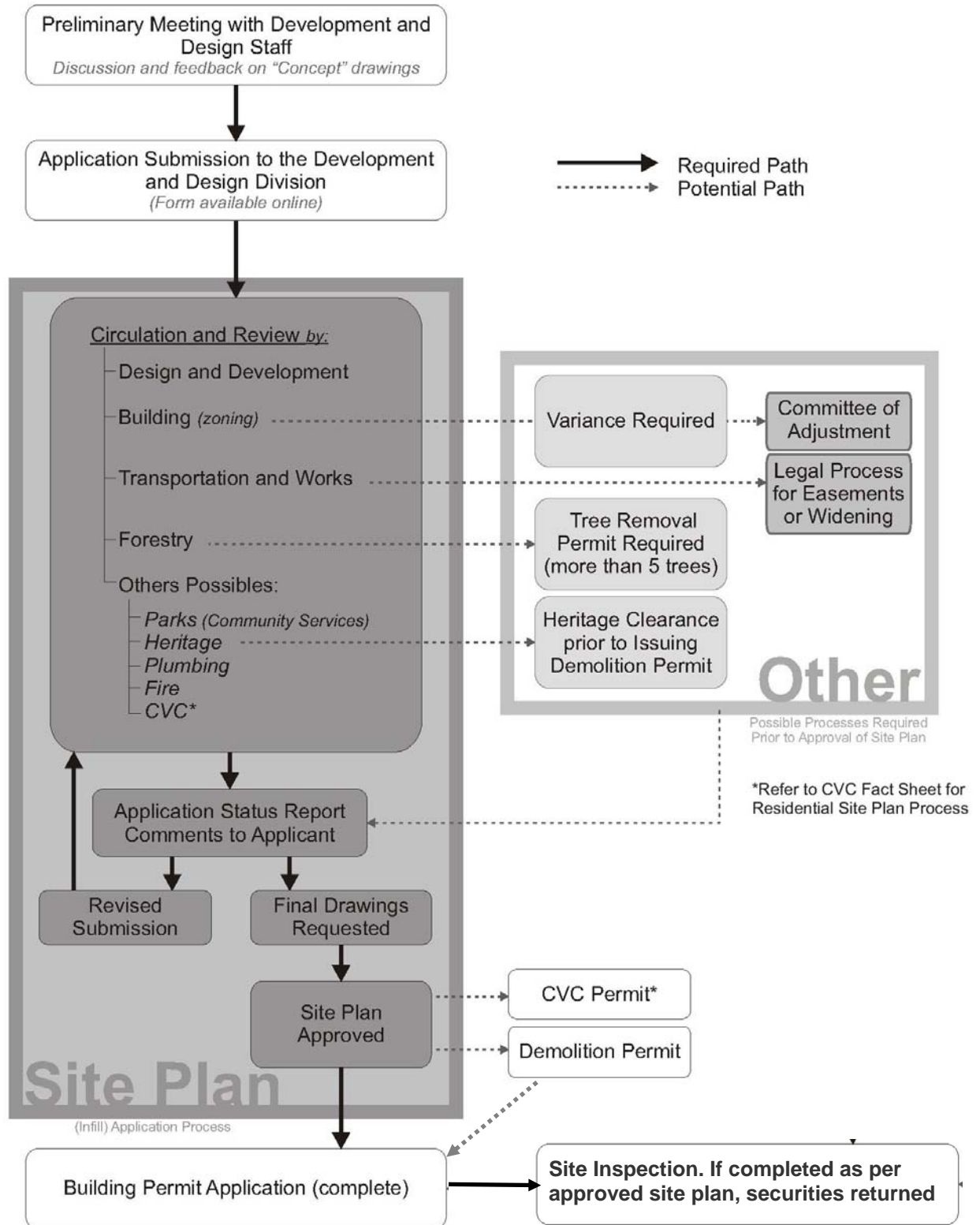

3.2

Who Gets Circulated

Depending on the type of site plan submitted, some or all of the following departments and agencies may be requested to comment on the application:

- > **Planning and Building Department-
Development and Design Division** - responsible for the coordination and review of all aspects of site design and landscaping, including but not limited to built forms, building elevations, site layout, natural features, vehicular and pedestrian circulation, impact on adjacent land uses. (Contact (905) 896-5511);
Building Division, Zoning Section- responsible for ensuring plans comply with the provisions of the City's Zoning By-law with respect to permitted uses, building setbacks, etc. (Contact (905) 896-5511 option #2); **Plumbing Section**- responsible for septic system review (Contact (905) 896-5511 option #1)
- > **Transportation and Works Department** - responsible for the review of the site plan for grading, drainage, driveway locations, road widenings, along with the impact of the proposed development on existing roadways and to identify any required modifications. (Contact (905) 615-4950);
- > **Community Services Department** –
Urban Forestry - responsible for the assessment of trees within the City boulevard. Also responsible for the issuance of tree permits and tree removal permissions. (Contact (905) 615-4100);
Parks Planning - responsible for the assessment of fencing, tree protection and grading in regards to properties adjacent to parkland and public open space. (Contact (905) 896-5382);
Culture Division - responsible for reviewing dwellings that impact properties that are listed on the City's *Heritage Register* or designated under the *Heritage Act*. (Contact (905) 615-3200 ext. 5314);
Fire Prevention - will review site plans when the travel distance from the edge of the road to the main entrance is more than 45 m (148 ft.) (Contact (905) 896-5908).
- > **Conservation Authorities** - responsible for the review of impacts on floodplains, valley lands and bank stability, stormwater management, erosion and sedimentation. (Credit Valley - Contact (905) 670-1615, Toronto and Region - Contact (416) 661-6600, Halton Region - Contact (905) 336-1158);
- > **Utility Companies** - Bell Canada, Enbridge Gas, Rogers Cable and Enersource Mississauga (not all applications go to each utility, and some are sent for information only);
- > **Ward Councillor** -For Information purposes only

3.3

Site Plan Application Requirements

The City of Mississauga recognizes that the development of new dwellings, replacement housing and/or additions in the Site Plan Control areas is unique for each proposal. We therefore require that applicants set up preliminary meetings with the Development and Design Division to ensure that their proposal meets these guidelines. The number of drawings required for the submission will be determined at this time.

The following are general requirements for the submission of a Site Plan Application:

An Application for Site Plan Approval can be picked up at the Development and Design Counter, Planning and Building Department or found on the City's website at www.mississauga.ca/siteplan.

3.3.1 Site Plan Drawings Requirements

- > Use a scale that is legible (1:200 is preferred). All drawings must be in metric and include a north arrow; (Plans must be folded to 8 ½ " x 11" size. Rolled drawings will not be accepted);
- > Include a Key Plan indicating the location of the subject property in relation to the closest major intersection;
- > Clearly indicate the applicant's and/or owner's name, address, and telephone number in the title block, along with the project name, municipal address, and legal description;
- > Show the location of the new house, additions proposed and/or new accessory buildings and structures for the property. The site plan should highlight all changes that are being proposed to the site;
- > Show the location of the existing house and all other structures on the site. Also show existing fencing, retaining walls and free standing walls;
- > Indicate all bearings and dimensions of the property;
- > Clearly show all building setbacks (shortest distance) to all lot lines and rights-of-way (including overhead building awnings);
- > Include site statistics (i.e. lot number, plan concession number, municipal address, lot area and at the street line, frontage at 7.5 m (24.6 ft.), lot coverage (proposed and permitted), applicable gross floor area (proposed and permitted), building heights, etc.);

Site Plan Requirements

Site Plan Drawings Requirements—Cont'd

- > Show existing and proposed grading information. Indicate if the grading is to remain the same or whether it will be modified (include existing and proposed spot elevations within the site boundaries, at the property lines, at corners of the proposed building, at top and bottom of retaining walls, and at the base of trees to be preserved). Also indicate the finished floor elevations;
- > Indicate adjacent land uses, zoning and the location of existing structures;
- > Indicate if you are proposing/contemplating installing a swimming pool. Indicate pool enclosure permit number where applicable. A swimming pool enclosure certificate of approval will need to be obtained. For additional information refer to the Residential Swimming Pool Installation Handbook found on the City's website at www.mississauga.ca/poolinstallation.
- > Include the names of abutting streets. Show the municipal boulevard in front of the subject property;
- > Show any easements or right-of-ways on the property along with a copy of the easement restrictions;
- > Show the location of all trees on site, neighbouring trees around the perimeter of the site and trees within the municipal boulevard. Include details such as the species, diameter, canopy size, and calliper. Additional information and Frequently Asked Questions regarding tree information can be found on the City's web site at www.mississauga.ca/urbanforestry. Show the location of any existing and proposed underground and above ground utilities;
- > Show the location of all existing and proposed septic systems including the septic tank and bed/mantle;
- > Show the type and dimension of the location of the existing and proposed driveway and walkways. An Access Modification Request Application is required by Transportation and Works Department for approval of curb cuts or modifications to existing approved access points. For residential properties subject to Site Plan Control, such applications are circulated to the Planning and Building Department for comments. For additional information contact the Transportation and Infrastructure Planning Division at 905-615-4950;
- > Show the location of proposed siltation control fencing and tree protection hoarding;
- > Show the location of material storage and construction access around the building.

Site Plan Drawings Requirements—Cont'd

3.3.2 Building Elevations

- > Include building elevation drawings of any side of the dwelling that is affected by the proposal (drawings for all 4 sides are preferred);
- > Indicate existing and proposed materials and colours for the walls and roof;
- > Show the heights of the eaves and the overall height from the average e grade;

Indicate the pitch of the roof.

3.3.3 Floor Plans

- > Show the proposed and existing uses for the spaces (i.e., kitchen, laundry, bedroom, etc.);
- > Indicate building dimensions;
- > Include a roof plan, showing the pitch of the roof.

3.3.4 Standard Notes on the Site Plan

In addition to the preceding general requirements, a number of standard notes must be included on the site plan drawing:

- > "I hereby certify that this drawing conforms in all respects to the site development plans as approved by the City of Mississauga under file number SP XX/XXX WX." [Site Plan number to be filled in after assigned] [Architect's, Engineer's, or Owner's Original signature];
- > "The City of Mississauga requires that all working drawings submitted to the Building Division as part of an application for the issuance of a building permit shall be in conformity with the site development plan as approved by the City of Mississauga, Development and Design Division." ;
- > "The Owner is responsible for ensuring that tree protection hoarding is maintained throughout all phases of demolition and construction in the location and condition as approved by the Planning and Building Department. No materials (building materials, soil, etc.) may be stockpiled within the area of hoarding. Failure to maintain the hoarding as originally approved or the storage of materials within the hoarding will be cause for the Letter of Credit to be held for two (2) years following completion of all site works." [Owner's original signature. Stamps or copies of signatures are not permitted on the final copies for Site Plan Approval];

Site Plan Requirements

Site Plan Drawings Requirements—Cont'd

- > “Should the installation of below ground services require hoarding to be removed, Planning and Building staff are to be contacted prior to the commencement of such work. Should an alternative service route not be possible, staff will inspect and document the condition of the vegetation and servicing installation in order to minimize damage to the vegetation.”;
- > “The structural design of any retaining wall over 0.60 m (2.00 ft.) in height or any retaining wall located on a property line is shown on the Site Plan and Grading Plan and is to be approved by the Consulting Engineer for the project.”;
- > “Grades must be met within 33% maximum slope at the property lines and within the site.”;
- > “The portions of the driveway within the municipal boulevard will be paved by the applicant.”;
- > “At the entrances to the site, the municipal curb and sidewalk will be continuous through the driveway and a curb depression will be provided for each entrance.”;
- > “All proposed curbing at the entrances to the site is to stop at the property line or at the municipal sidewalk.”;
- > “The existing drainage pattern will be maintained.”;
- > “All utility companies will be notified for locates prior to the installation of the hoarding that lies within the limits of the City boulevard area.”;
- > “The applicant will be responsible for the cost of any utilities relocations necessitated by the Site Plan”;
- > “Construction materials are not to be put out for collection.”;
- > “All damaged landscape areas will be reinstated with topsoil and sod prior to release of securities.”;
- > “All excess excavated materials will be removed from the site.”;
- > “There are no existing or proposed easements on the property” (if applicable).
- > Once all works are complete, the applicant is to contact the Planning and Building Department, Development and Design Division, at (905) 896-5511 for an Inspection **PRIOR** to hoarding being removed.

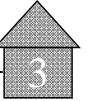

3.4

Securities

As a condition of site plan approval, the Development and Design Division may request securities to ensure that tree protection and site works complies with the approved plans. As indicated below, the amount of securities will vary depending on the extent of the proposed development and site works:

Minor Additions: (includes tree protection/hoarding with no changes to the driveway) \$5,000 - \$10,000

Major Additions: (includes tree protection and replanting and driveway reconfigurations) \$10,000 - \$15,000

New/Replacement Dwellings under 400 sq m (4,305 sq.ft.) (includes tree protection and replanting and driveway configurations) \$15,000 - \$25,000

New/Replacement Dwellings 400 sq m (4,305 sq. ft.) or greater (includes tree protection and replanting and driveway reconfigurations) \$25,000 - and up

It is anticipated that some site plan applications may vary from the above criteria. In these cases, it will be at staff's discretion to determine the appropriate amount of securities for the site.

Once the exterior cladding is complete and all site works have been installed, the homeowner should contact the Development and Design Division to arrange for an inspection to initiate the release of the securities.

3.4.1 City Owned Trees

The Community Services Department, **Urban Forestry Section** may require additional securities to ensure the protection and preservation of City owned trees within the municipal boulevard adjacent to the site. The amount of securities will be determined through the site plan process, and may be collected by the Development and Design Division on behalf of Urban Forestry. The **Parks Planning Section** may require additional securities for the protection and preservation of City owned lands when an application is adjacent to parkland or a greenbelt. The amount will be determined and taken by this section.

3.4.2 Transportation and Works

Additional securities may be required by the Transportation and Works Department through the site plan and building permit processes. For further information, please contact the Transportation and Works Department at 905-615-4950.

3.4.3 Payment of Securities

Acceptable Letters of Credit must be drawn from a bank set out in Schedule 1 of the *Bank Act* (R.S.C. 1985, C.B-1.01, and any amendments thereto) or a bank listed in Schedule 2 of the *Bank Act* (R.S.C. 1985, C.B-1.01, and any amendments thereto) having a Dominion Bond Rating Service of R-1.

Certified cheques, bank drafts or cash are also acceptable forms of security. Visit the City's website at www.mississauga.ca/siteplan.

Payment of securities must be fulfilled prior to Site Plan Approval.

3.5 Hoarding

Hoarding is a technique of installing temporary fencing around trees that are to be protected during construction. The hoarding must be indicated on the site plan and must be installed and inspected by the Development and Design Division's Landscape Architectural Technologist prior to site plan approval.

Framed Hoarding

Framed hoarding is defined as plastic safety fencing supported by iron "T" stakes at 2.0 m (6 ft. 7 in.) on centre and supported with a wooden frame of 1x3 slats across the top and bottom.

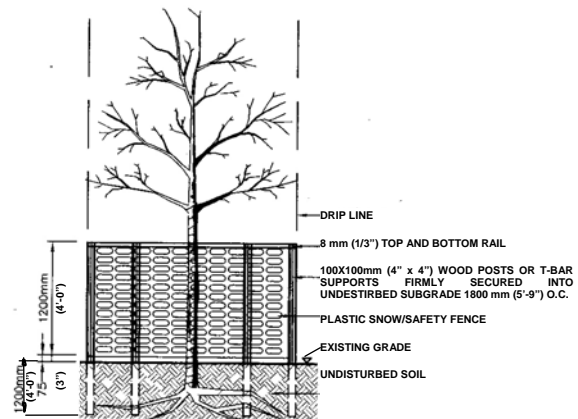

Solid Hoarding

Solid hoarding is defined as a solid wood structure/fence, generally of plywood, with a minimum height of 1.2 m (4 ft.).

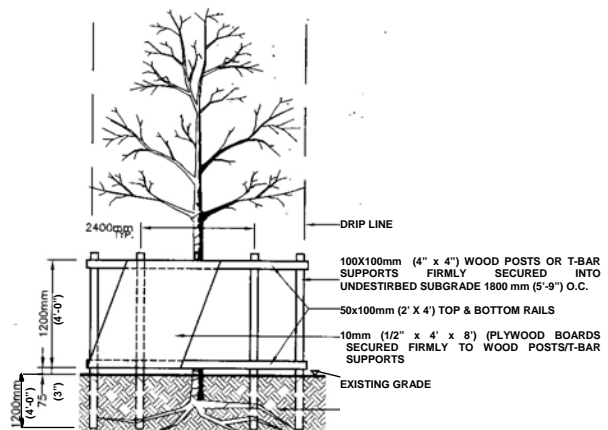

Other departments may require additional hoarding and sediment control fencing. Please contact the City's Transportation and Works and Community Services Department for information on their hoarding requirements.

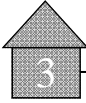

Site Plan Requirements

3.6 Tree Removal Permission

The City of Mississauga has passed By-law 0474-2005 regulating the removal of trees on private property. The By-law states that property owners require a permit to remove five or more trees that are 15 cm (6 inches) in diameter or larger from their private property in a calendar year. Trees should not be removed prior to submitting an application.

For more information contact 905-615-3200 ext. 4100 or go to www.mississauga.ca/siteplan. For the application to permit the Injury or Destruction of Trees on Private Property go to www.mississauga.ca/siteplan.

3.7 Site Plan Undertaking

A Site Plan Undertaking is an agreement between the property owner or corporation and the City to ensure that the proposed house or addition is built in conformity with the plans approved by the Planning and Building Department, Development and Design Division. A copy of the Site Plan Undertaking can be found on the City's website at www.mississauga.ca/siteplan or www.mississauga.ca/siteplan or can be obtained from the Development and Design Division, 11th floor or at 905-896-5511.

The Site Plan Undertaking must be signed and the original copy must be submitted prior to site plan approval.

3.8 Length of Site Plan Approval

Site Plan Approval is valid for one (1) year from the date of approval by the Development and Design Division. If a building permit is not issued during this time, Site Plan approval is void.

The Development and Design Division may upon written request consider an extension of Site Plan Approval and may grant an extension. If an extension is not issued, a new application will be required.

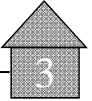

3.9

Site Work Inspection

Upon completion of all site works including grading, sodding and driveways, the applicant is to contact the Landscape Architectural Technologist, Planning and Building Department to arrange a site inspection.

If applicable, the applicant may also be required to contact Urban Forestry and/or the Parks Planning Sections of the Community Services Department, to inspect the completed site works for the release of securities held for City owned tree protection and parkland/open space protection and fencing. Further, if Transportation and Works Department approval was required, a site inspection may also be required, depending on the nature of the issues and/or if securities were required.

If hoarding is removed without notification to the Development and Design Division and stockpiling and soil/construction materials are found in proximity to trees, Securities may be held for an additional two years.

Final approval of site works and release of securities are carried out between May 1 and October 31.

Changes to the property which are not reflected on the site plan approval may require the submission of an "as built" site plan and/or Site Plan Revision application.

Securities may be drawn upon by the City if steps are not taken by the owner to complete all site works or rectify deficient site works.

Upon acceptance of the site works, the securities are returned to the applicant.

3.10 Glossary of Terms

Broken down wall planes:

Speaks to encouraging the front walls of a dwelling to include features such as porches, dormers and bay windows to eliminate a flat wall treatment.

Building massing:

Refers to the volume of the proposed house as defined by its overall length, width and height.

Building setback:

The measurements that define the minimum distance of a house from the closest property lines. These measurements will include the front, side and rear yard setbacks. This is to ensure conformity with the zoning by-law setbacks.

Drip line of the trees:

Is the line representing the outermost limits of the tree branches. This information is required in instances where tree preservation is a priority.

Frontage:

The portion of the lot width that abuts the street. In the case of an irregular lot shape, the frontage is the lot width measured 7.5 m (24.6 ft.) back from the front property line.

Tree caliper:

Caliper is the stem thickness of a tree trunk measured 15 cm (6 inches) above ground. Trees over 10 cm (4 inches) in caliper are measured 30 cm (12 inches) above ground.

Finished floor elevation:

The measurements that relate the height of the first floor of a house above the existing or altered lot grades.

Site Plan Requirements

3.11 Sample Site Plan

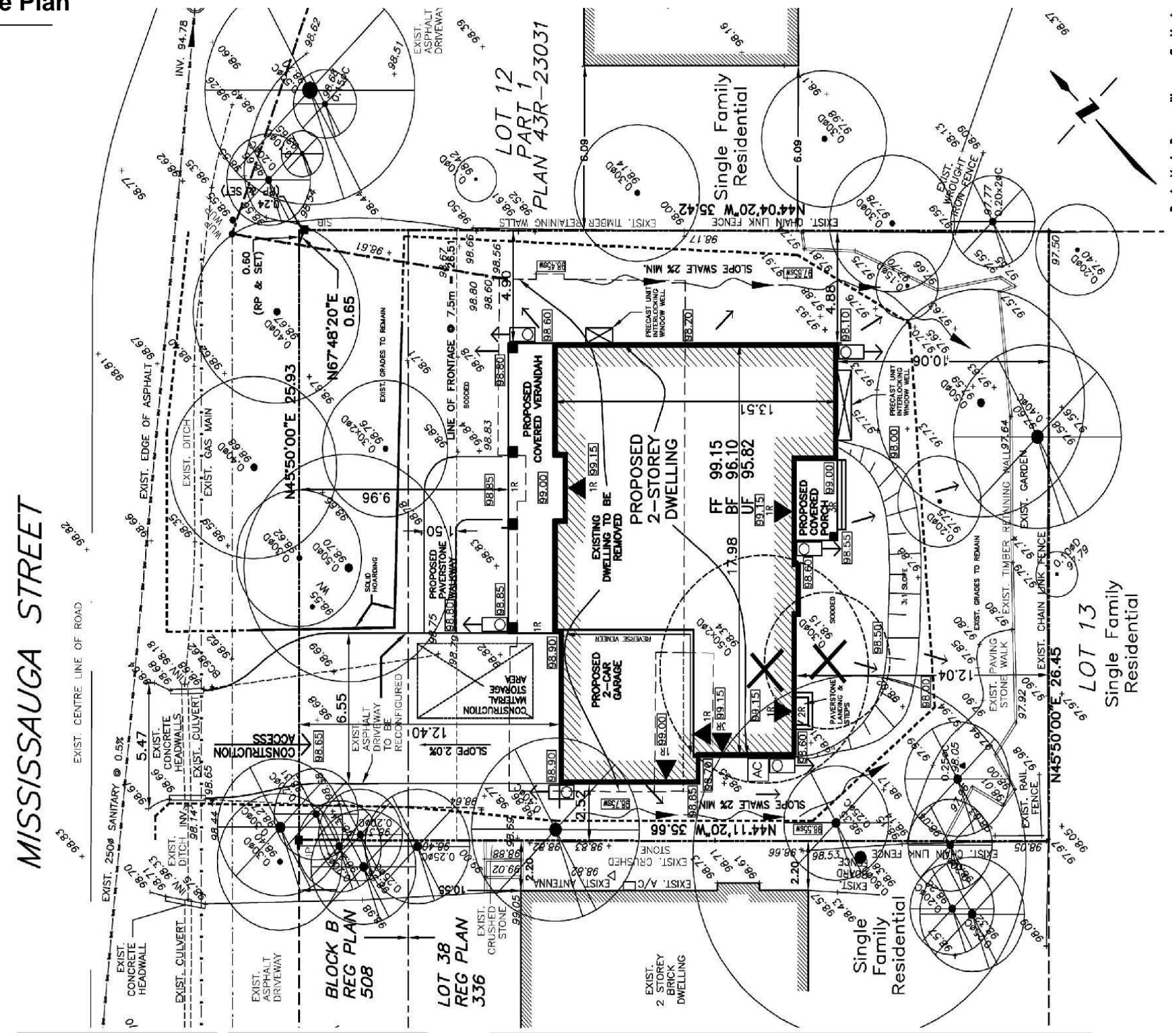

- Key Plan
- Standard Notes:
- Legend:
- Site Data:
- Established Grade Calculations:
- Hoarding Details:
- Other
- Show the location of the septic information if any:
- Owners Name, Address etc:
- Revisions:
- Title Block:
Name, Address, etc

Site Plan Requirements

3.12

Sample Building Elevations



PROPOSED FRONT ELEVATION

EXTERIOR COLORS
 STONE - GREY / BROWN
 SHINGLES - SHUTWOOD
 STUDS - MEDIUM TAUPE
 GARAGE DOORS - DARK TAUPÉ
 FRONT DOOR - NATURAL
 WINDOWS / TRIM - WHITE
 ALUM. SASHES - CLAY

SITE PLAN APPLICATION No. SPI _____

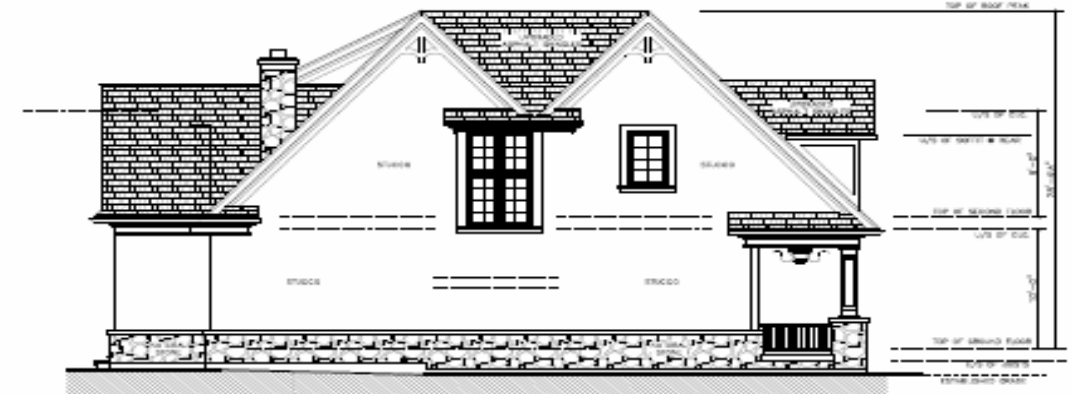

PROPOSED LEFT-SIDE ELEVATION

EXTERIOR COLORS
 STONE - GREY / BROWN
 SHINGLES - SHUTWOOD
 STUDS - MEDIUM TAUPE
 GARAGE DOORS - DARK TAUPÉ
 FRONT DOOR - NATURAL
 WINDOWS / TRIM - WHITE
 ALUM. SASHES - CLAY

SITE PLAN APPLICATION No. SPI _____



PROPOSED RIGHT-SIDE ELEVATION

EXTERIOR COLORS
 STONE - GREY / BROWN
 SHINGLES - SHUTWOOD
 STUDS - MEDIUM TAUPE
 GARAGE DOORS - DARK TAUPÉ
 FRONT DOOR - NATURAL
 WINDOWS / TRIM - WHITE
 ALUM. SASHES - CLAY

SITE PLAN APPLICATION No. SPI _____



PROPOSED REAR ELEVATION

EXTERIOR COLORS
 STONE - GREY / BROWN
 SHINGLES - SHUTWOOD
 STUDS - MEDIUM TAUPE
 GARAGE DOORS - DARK TAUPÉ
 FRONT DOOR - NATURAL
 WINDOWS / TRIM - WHITE
 ALUM. SASHES - CLAY

SITE PLAN APPLICATION No. SPI _____

Site Plan Requirements

3.13

Sample Floor



PROPOSED SECOND FLOOR PLAN

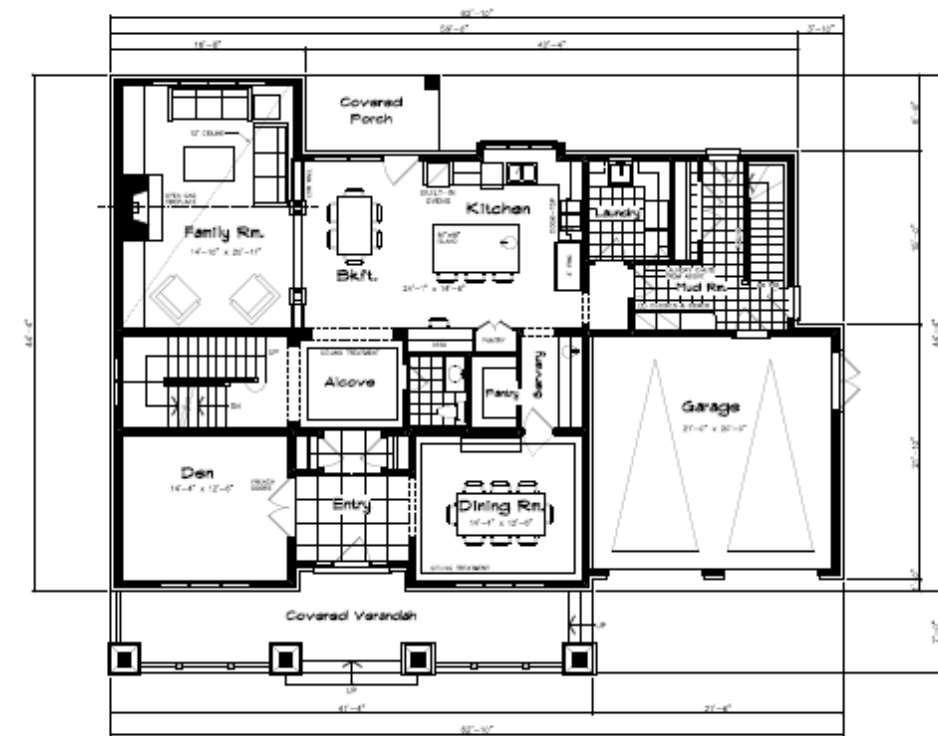

PROPOSED GROUND FLOOR PLAN

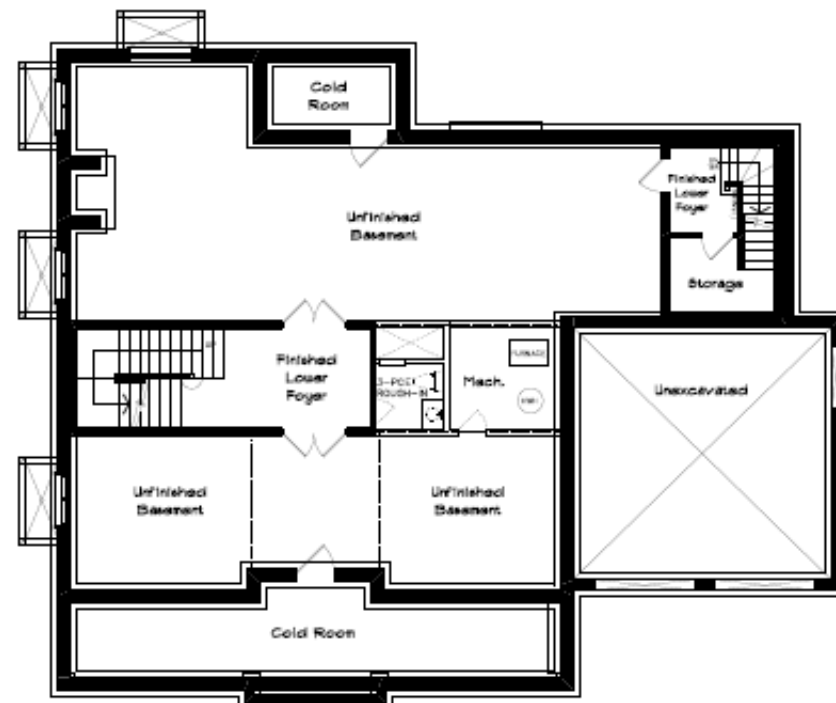

PROPOSED BASEMENT PLAN

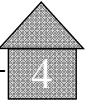

**PART 4.0
CONCLUSION**

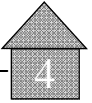

4.1 Keep your neighbours informed

The construction of new dwellings, replacement dwellings and additions typically impact existing neighbours. Immediate neighbours feel the impact of new larger homes or additions being constructed closer to their property lines. Construction immediately adjacent to their homes may not only negatively impact them visually, but may also physically impact them through noise and dirt from the construction site. Other residents throughout the neighbourhood may be impacted by the changes in the streetscape, the removal of well established trees, as well as by the noise and dirt of the construction.

Take the time to keep your neighbours properly informed of your plans, and when possible, provide them with a contact number so that they can ask questions or discuss any concerns they may have. Keep the construction site clean and safe.

Don't forget to follow the guidelines.

4.2 Guidelines for a successful project

- Make sure you have all the required approvals and permits;
- Talk to your neighbours and keep them informed;
- Ensure any required hoarding is up throughout the entire construction process and that the contractor is not disregarding the site plan approval by storing material or equipment in areas not designated as stockpiling and storage;
- Keep noisy work to allowable times see www.mississauga.ca/bylaws.
- Do not block driveways, public or private;
- Keep the construction site and surrounding area clean.

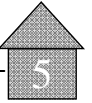

**PART 5.0
APPENDICIES**

5.3

Appendix 'A' - Average Grade Calculation

Definition as per Zoning By-Law No. 225-2007

“Average Grade” means with reference to a detached, semi-detached, duplex and triplex dwelling, the average of which (8) grade elevations, six (6) of which are taken along the side lot lines of a lot and two (2) of which are taken at the centerline of the street on which the lot has frontage. The first two (2) grade elevations shall be take at the points of intersection of the front lot line and each side lot line. The second two (2) grade elevations shall be taken along each side property line at the minimum front yard setback requirement of the zone in which the property is located. The third two (2) grade elevations shall be taken along each side property line at a distance of 15.0 m back from where the second two (2) grade elevations were measured. The last two (2) grade elevations shall be taken at the point of intersection of the street centerline and the projections of the side lot lines.

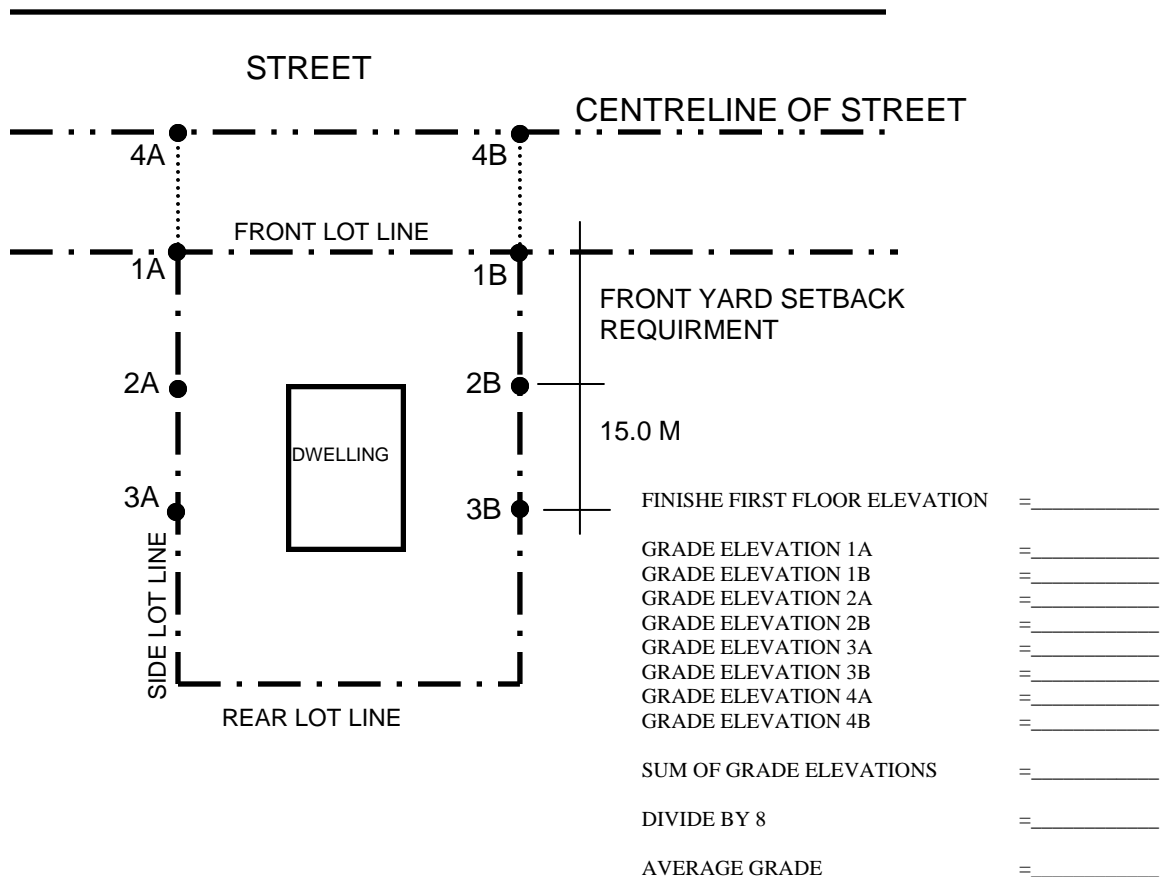

5.4

Appendix 'B' - Credit Valley Conservation Process Chart



Credit Valley Conservation (CVC) Residential Site Plan Process for Properties within Regulated Areas

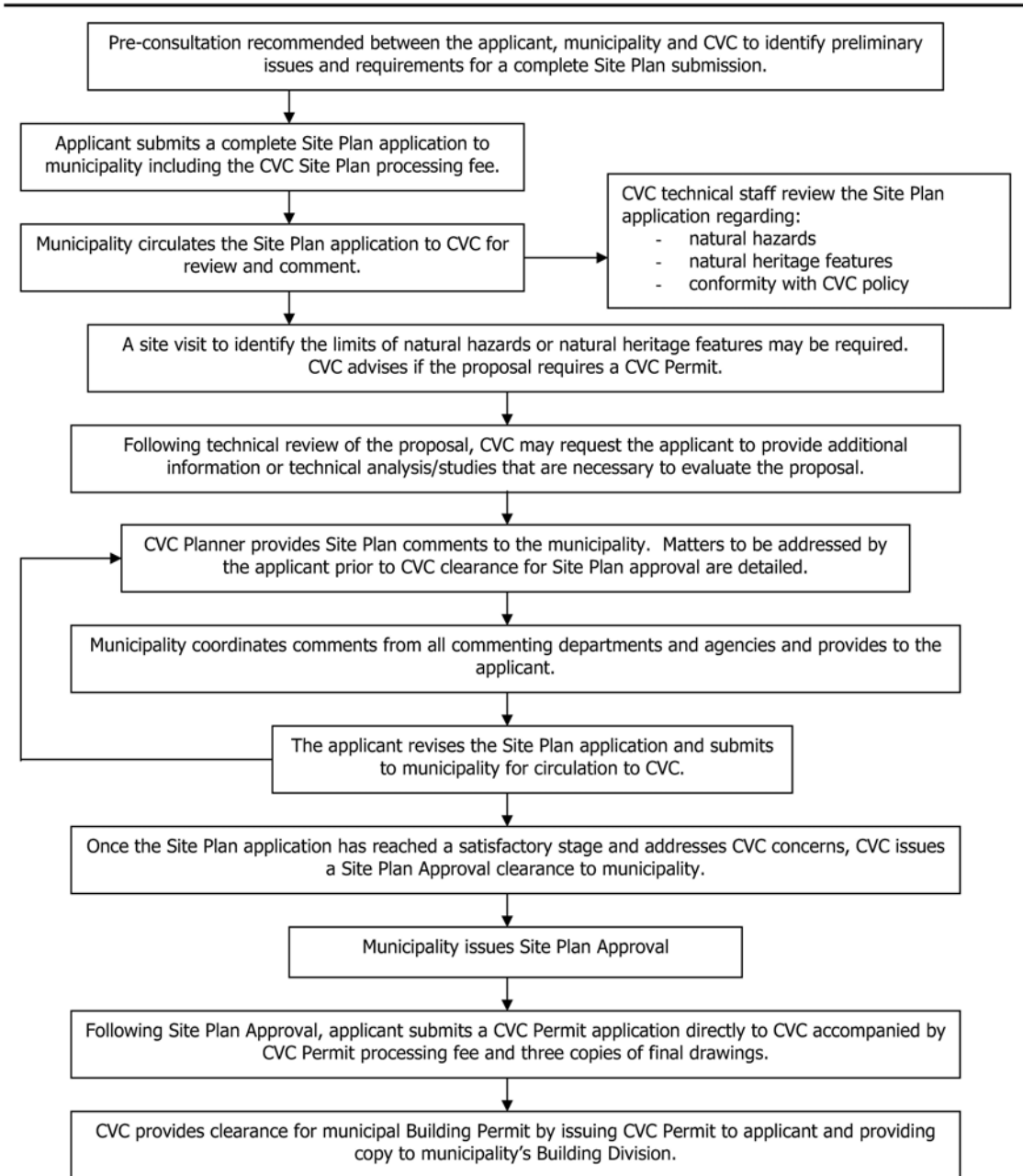

NOTE: Missing pages are blank pages in the printed document.